

GCC0W-4820

SPECIFICATIONS



CS WATERPROOF LEAD ACID BATTERY CHARGER

48V 20A - No outlet connector



Electric Golf Carts



Electric Beach Car



Sightseeing Tour Car



Small Boat



Electrical Tricycle



Forklift



Electric Car

Our 3-stage battery charger is intelligent, safe and durable. Advanced high frequency switching mode power supply technology, designed to supply necessary power and energy to your Golf Cart Battery for sports and holiday activities. With precise voltage & current, the GCC0W-4820 is guaranteed to fully charge and not over charge. A sturdy aluminium shell allows for long lasting performance. This battery Charger can work normally under 58.8Vdc/20A and with reverse polarity protection.

FEATURES

- Up to 91% work efficiency
- Strong protection function
- Working temperature scope of wide temperature range
- 100% full loading aging test
- Quake proof degree of automotive grade
- 100% full load burn-in test
- Output over voltage protection
- Output over current protection
- Output short-circuit protection
- Reverse polarity protection
- Charger over temperature protection
- Forced ventilation with fans

STORAGE

The charger must be energized every three months for no less than 50 minutes when not in use.



www.csaf.co.za

Charging Systems Africa Pty Ltd
info@csaf.co.za | 011 447 1370

INTERFACE DESIGN

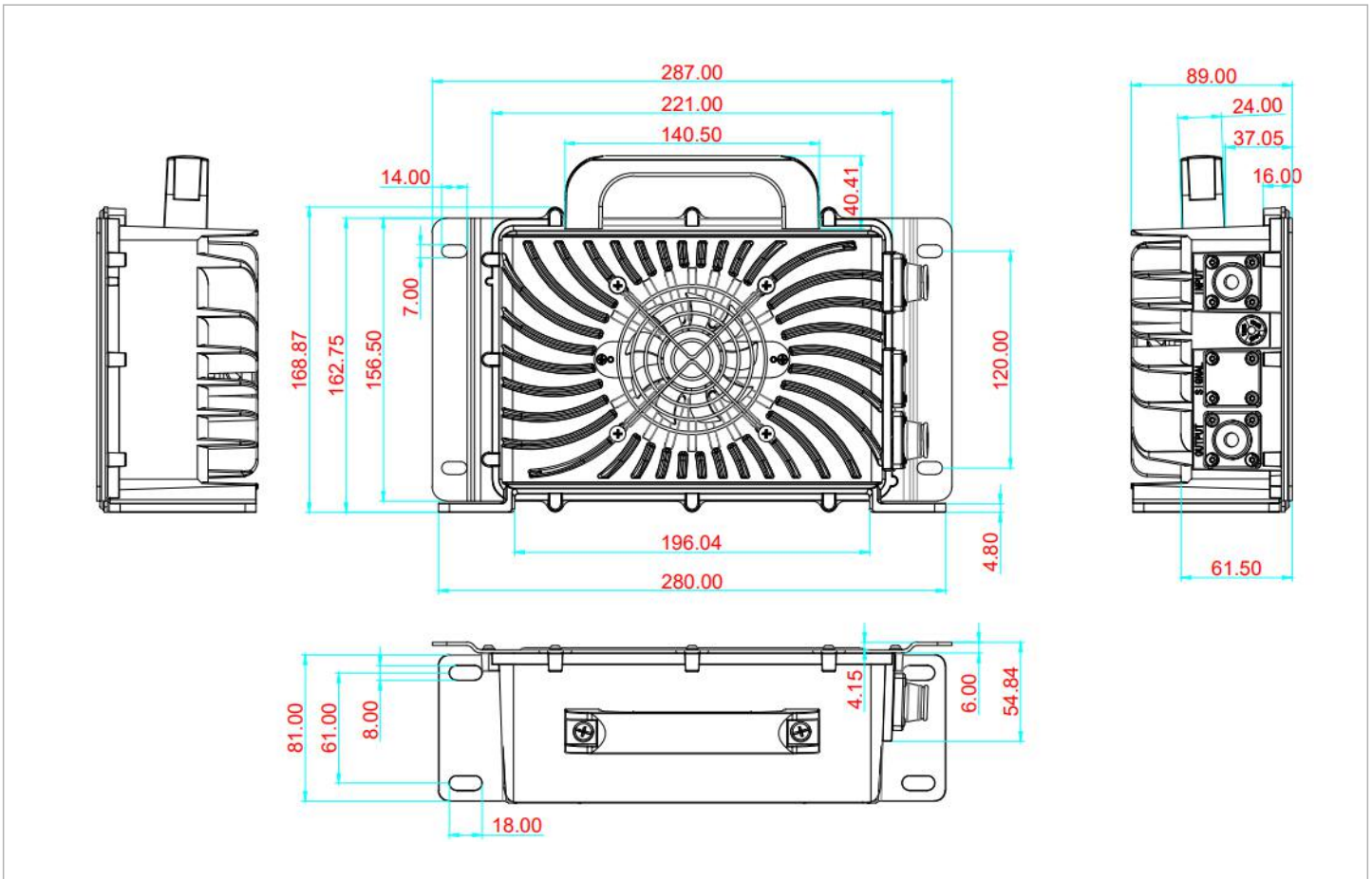
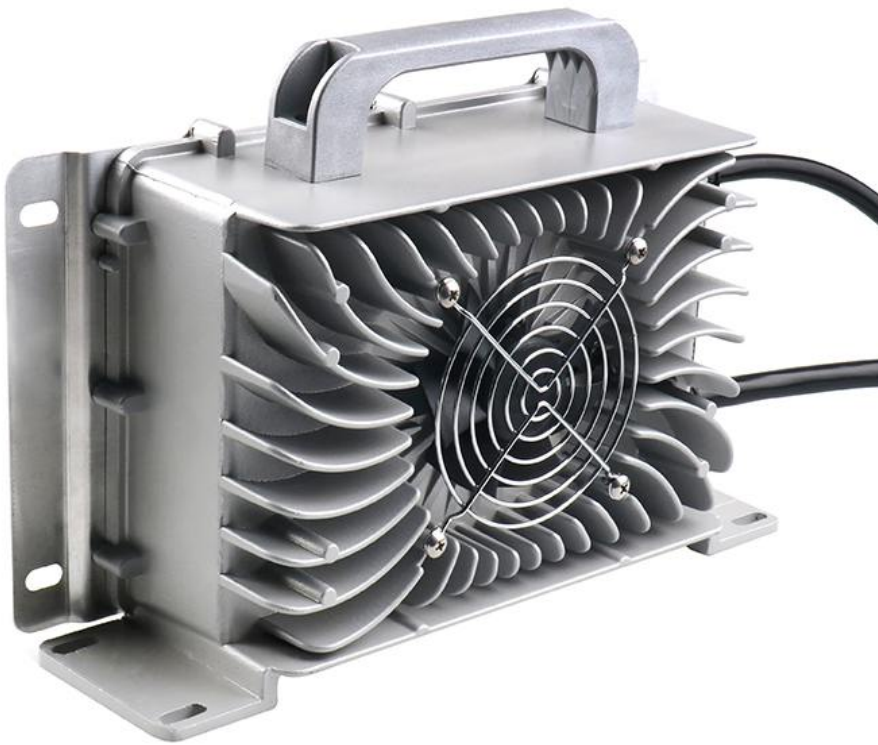

TECHNICAL SPECIFICATIONS

MODEL		GCC0W-4820
MAIN PRODUCT SPECIFICATIONS		
Battery Type	Lead Acid	
Max output voltage	58.8V± 0.2V	
Output Current	20A± 0.2A	
Input Voltage	220Vac	
INPUT CHARACTERISTICS		
Rated input voltage	220Vac	
Input voltage range	200-240Vac	
Input voltage frequency	50-60 Hz	
OUTPUT CHARACTERISTICS / CHARGE STAGES		
CC (constant current)	20A	
CV (constant voltage)	58.8V± 0.2Vdc↓	
Float charge voltage	yes	
Transition current	4A± 0.2A	
Power efficiency	≥ 91% (Vin=220Vac rated load)	
PROTECTION CHARACTERISTICS		
Over voltage protection	Yes. The maximum output voltage set by the charger will not exceed the maximum charging voltage of the battery	
Thermal protection	When the working temperature is higher than 85 °C, the power will be reduced by 50%~80%. The charger can recover automatically until the temperature drops below 60 °C	
Current limiting protection	Yes. At CC mode	
Short circuit protection	Short circuit protection should automatically recover after removing the fault and restarting the charger	
Reverse polarity protection	When the output is reversed, the charger will not work until the user connects it correctly and plugs in the power again. "Non-zero volt start charging"	
CHARGING INDICATOR		
Standby (no output)	★ ★ Green Yellow - slow flashing	
Charging <80%	● Red on	
Charging >80%	● Yellow on	
Fully Charged	● Green on	
Charging voltage display	No	
Charging current display	No	
PROTECTION INDICATOR		
Over voltage/current protection	★ ★ Green Yellow - fast flashing	
Abnormal output	★ ★ Green Yellow - fast flashing	
Output short circuit protection	★ ★ Green Yellow - fast flashing	
Battery voltage below 30%	★ ★ Green Yellow - fast flashing	
ENVIRONMENTAL CONDITION		
Operation temperature	-10 ~ +45°C	
Humidity	5 ~ 95%	
Storage temperature	-40 ~ +70°C	
Altitude	0 ~ 3000m	
Cooling	External Fan	

TECHNICAL SPECIFICATIONS

MODEL		GCC0W-4820	
SAFETY & EMC		STANDARD (OR TEST CONDITION)	
Electric strength test	Input-Output	1500Vdc/1min	Can withstand DC voltage 1500V, 1 minute Leakage current $\leq 2\text{mA}$ No breakdown or arcing
	Input-Earth	$\leq 2\text{mA}$	
Isolation resistance	Output-Earth	$\geq 10\text{M}\Omega@500\text{Vac}$	Input to output, input to case 500Vdc & normal air pressure, tested in relative humidity 90%
	Output-Shell		
EMI	Conduction	<input type="checkbox"/> EN55014 <input type="checkbox"/> EN55022	150k~30MHz
	Radiation	<input type="checkbox"/> EN55014 <input type="checkbox"/> EN55022	30M Hz~1GHz
	Power Clamp	<input type="checkbox"/> EN55014 <input type="checkbox"/> EN55022	30M Hz~1GHz
Safety		CE ROHS	

ENVIRONMENTAL TESTING REQUIREMENTS	
Waterproof grade	IP67
High temperature ambient operating	+45°C
Low temperature ambient operating	-10°C
High temperature storage	+70°C
Low temperature storage	-40°C
Random vibration	20Hz to 2000Hz 3Grms, 20hours per axis
Repetitive shock	40g peak 3 orthogonal axes, 3+ and 3- in each axes, 11ms pulse width
Thermal shock	-35°C to 75°C, <3min transition, 2.5hours dwell, 200cycle
Drop test	BS EN60068-2-32:1993 TEST, ED: free fall appendix B

MECHANICAL CHARACTERISTICS	
Shell material	Zinc Aluminum alloy
Input socket	South Africa plug (AC wire 1.5m)
Output socket	/ (DC wire 1.5m)
Dimensions (mm)	287(l) x 169(w) x 89(h)
Net weight	4.5kg (4500g)

RELIABILITY REQUIREMENTS	
MTBF	MTBF no less than 20000 hours (25 °C, full load and rated voltage input)
Burn-in and life test	At ambient temperature 25 °C aging in two hours, shell surface temperature ≤ 55 °C

CHARGING CURVE

