

INTELLI-IQ

SMART RELAYS

SINGLE-CHANNEL, MULTI-CHANNEL

LINBUS



IQMR4

IQR040

P/Nos. IQR040, IQMR4

WARNING

To ensure proper functionality and system stability, please follow the steps below in order:

- Before connecting any Smart Relays (P/No. IQR040, IQMR4) to the system, use the PROJECTA IQ APP to update the firmware of your IQ Controllers (e.g. IQD2) to the latest version (at least 1.1.X).
- Failure to do so may result in system freeze.
- After connecting the Smart Relays, use the PROJECTA IQ APP again to update the firmware of each relay unit.
- This step is essential to enable full feature compatibility and optimize system performance.

CONTENTS

1. INTRODUCTION	4
1.1 Features	4
2. PRODUCT OVERVIEW	5
3. SPECIFICATIONS	6
3.1 Dimensions	7
3.2 Application diagrams	8
4. SYSTEM SETUP WITH IQ	9
4.1 Main display screen layout	9
5. SMART RELAYS ON INTELLI-IQ APP INSTRUCTION	10
5.1 Setup the relays	10
5.2 IQR040 Setup	12
5.3 IQMR4 Setup	15
6. SMART RELAYS ON CARPLAY/ANROID AUTO INSTRUCTION	19

1. INTRODUCTION

The INTELLI-IQ ecosystem enhances power management solutions with the introduction of the IQR040 and IQMR4 Smart Relays, both featuring LIN bus integration for superior communication and device management.

The IQR040, a 40A Single Channel Smart Relay, is compatible with 12V and 24V systems and provides robust safety protocols for reliable performance.

The IQMR4 offers additional flexibility with its Multi-Channel control capabilities, designed to handle complex configurations.

1.1 Features

- LIN bus connectivity with INTELLI-IQ controller: Both the IQR040 and IQMR4 Smart Relays integrate seamlessly with the INTELLI IQ controller (like IQD2) via LIN bus connection, offering users sophisticated customization and control through the PROJECTA IQ App.
- Timer relays:
 - ~ Delay Off: deactivate devices with a set time delay, optimizing energy use and convenience.
 - ~ Daily task: program devices to turn on/off at specific times, like activating heating systems at 6AM on weekdays.
- Advanced lighting control:
 - ~ High beam trigger: integrates vehicle lighting with high beam operations, enhancing visibility and safety during night driving
 - ~ Flash patterns: includes 7 default patterns (SOS and etc.) and a custom mode allowing users to create unique on/off sequences, suitable for signalling and decoration.
 - ~ Brightness adjustment (IQMR4 only): tailors lighting levels for different settings, enhancing ambiance and energy efficiency.
- Voltage Sensitive Relay (VSR) (IQR040, 12V only): automatically adjusts the connection based on voltage criteria, crucial for maintaining stable operations.
- Current sensor with digital fusing (IQR040 only): monitors electrical flow, providing automatic cut-off at 40A to prevent overload, essential for high-power applications.
- Conditional switching (IQMR4 only): ensures that activating one channel automatically deactivates the linked channel. It's particularly effective in dual colour vehicle lighting, allowing seamless transitions between settings. Also, in RVs and 4X4s, it can switch from spotlight to floodlight automatically, adapting to changes in outdoor conditions.
- Comprehensive protection:
 - ~ Over and under voltage protection: guards against voltage irregularities.
 - ~ Load dump protection: shields against sudden discharge loads when an energy source is disconnected.
 - ~ Over temperature protection: prevents overheating by moderating temperature levels within the system.
 - ~ Low Voltage Disconnect (LVD): customizable settings to protect devices from voltage fluctuations, ensuring safety and prolonging device lifespan.
- Plug 'n play system: The system is designed for effortless integration in any PROJECTA LIN environment that recognize all LIN product range automatically with minimum user intervention. All PROJECTA LIN products can simply connect and ready to use.

2. PRODUCT OVERVIEW

IQR040



IQMR4

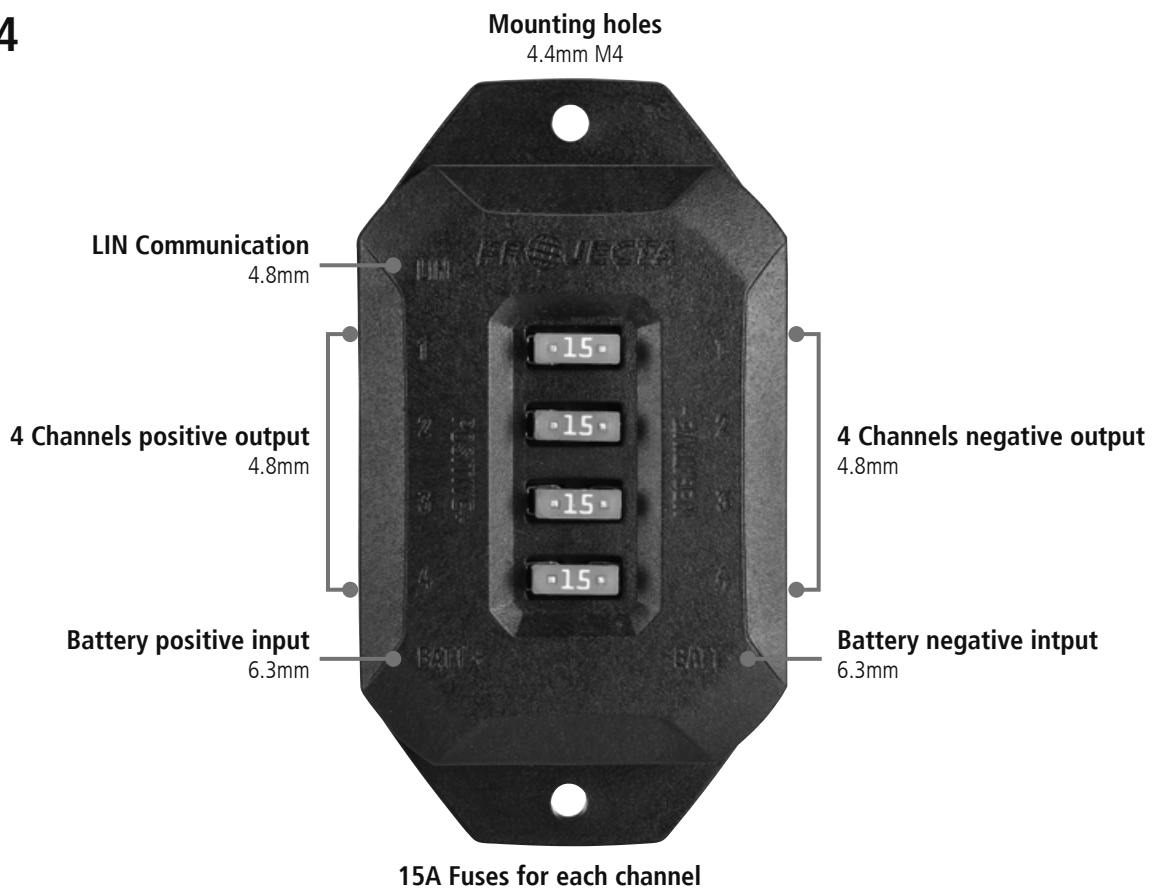

3. SPECIFICATIONS

PART NO.	IQR040	IQMR4
INPUT VOLTAGE RANGE	9-32V	9-16V
INPUT UNDER VOLTAGE PROTECTION	9.0V	9.0V
INPUT OVER VOLTAGE PROTECTION	>33V	>16V
INPUT CONSUMPTION CURRENT	<10mA	<10mA
MAX OUTPUT CURRENT	40A @12V, 15A@24V	10A max per channel, 30A max for total output
COMMUNICATIONS		
LIN BUS SUPPORT	2.1	2.1
LIN DEVICE TYPE	Slave/Peripheral	Slave/Peripheral
PHYSICAL CHARACTERISTICS		
OPERATING TEMPERATURE	-10 ~ 85°C	-10 ~ 85°C
OPERATING HUMIDITY	0~90%RH	0~90%RH
STORAGE TEMPERATURE (short term)	-10~105°C	-10~105°C
STORAGE HUMIDITY	<60%RH	<60%RH
IP RATING	IP68&IP69K	IP20
PRODUCT SIZE	59 x 52 x 46.5mm	102 x 56 x 23.3mm
PRODUCT WEIGHT	150g	90g
SAFETY		
	Thermal Protection Shutdown	Thermal Protection Shutdown
	Overvoltage Protection	Overvoltage Protection
	Undervoltage Protection	Undervoltage Protection
	Short Circuit Protection	Short Circuit Protection
	Reverse Connection Protection	Built-in 15A Fuse Holder per channel for Overcurrent Protection
STANDARDS		
	CISPR11-CLASS B, AS/NZS 4268, CE, ECE E10	CISPR11-CLASS B, AS/NZS 4268, CE, ECE E10

3.1 Dimensions

IQR040

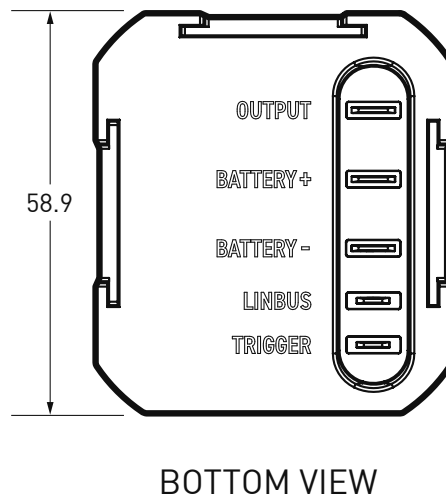
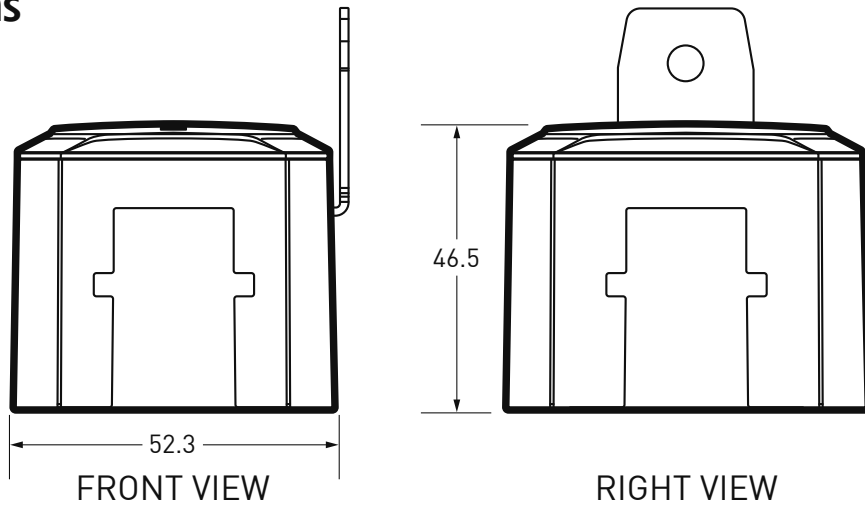

IQMR4

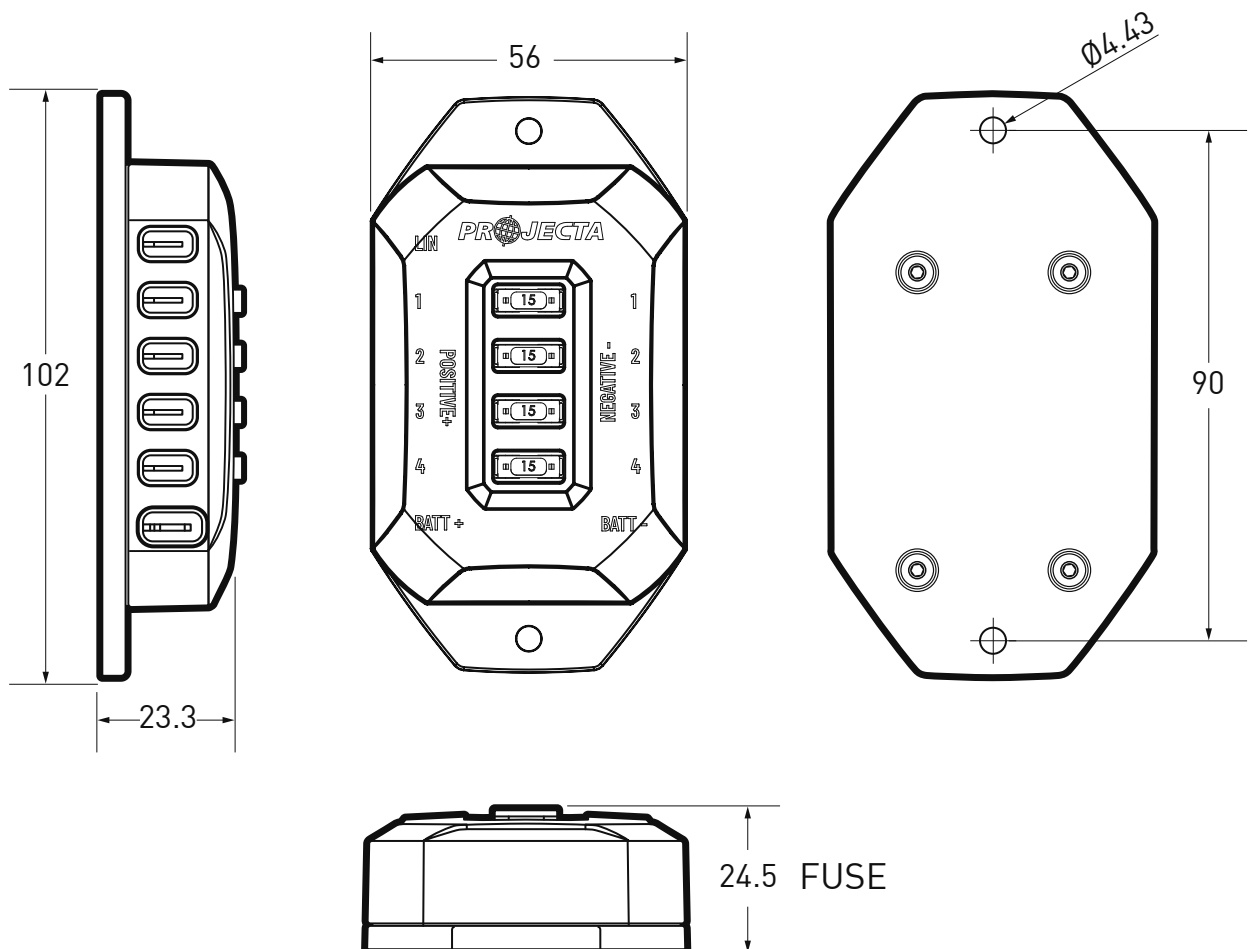

3.2 Application Diagram

IQR040

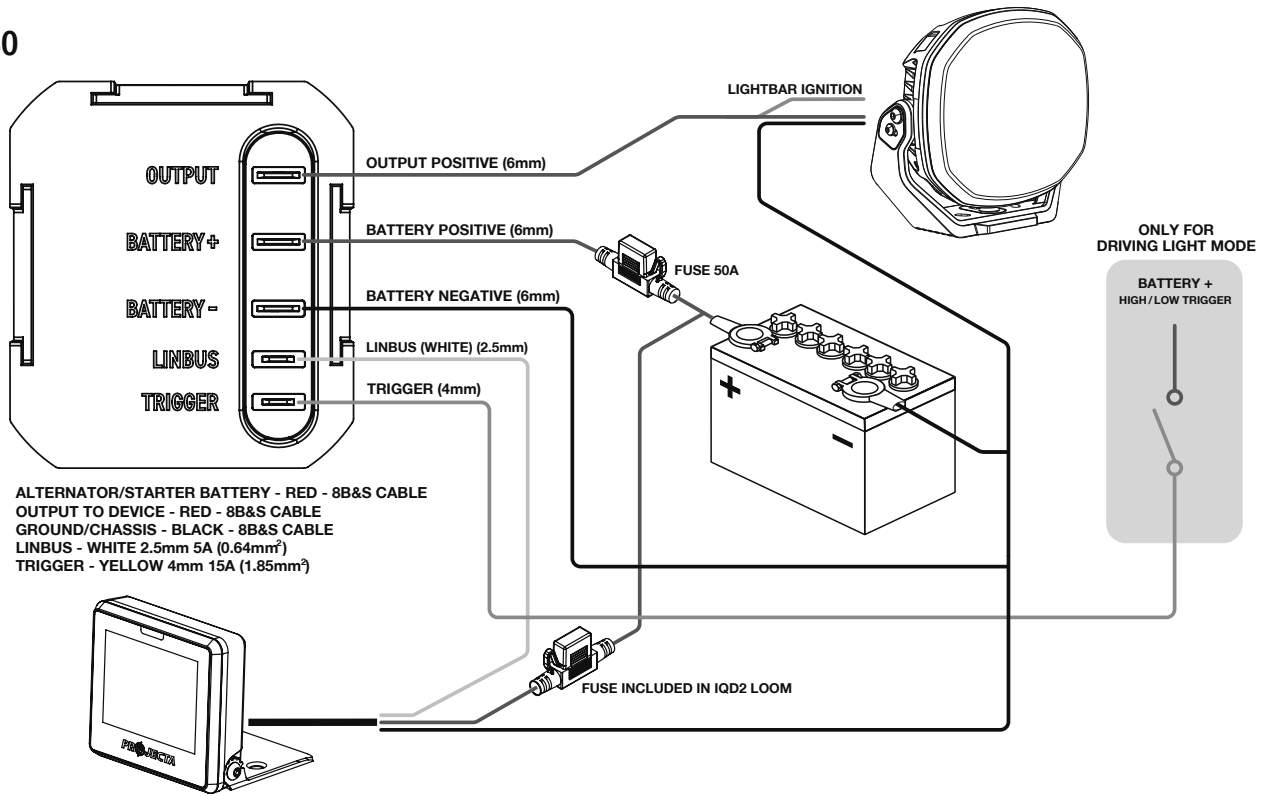

IQMR4

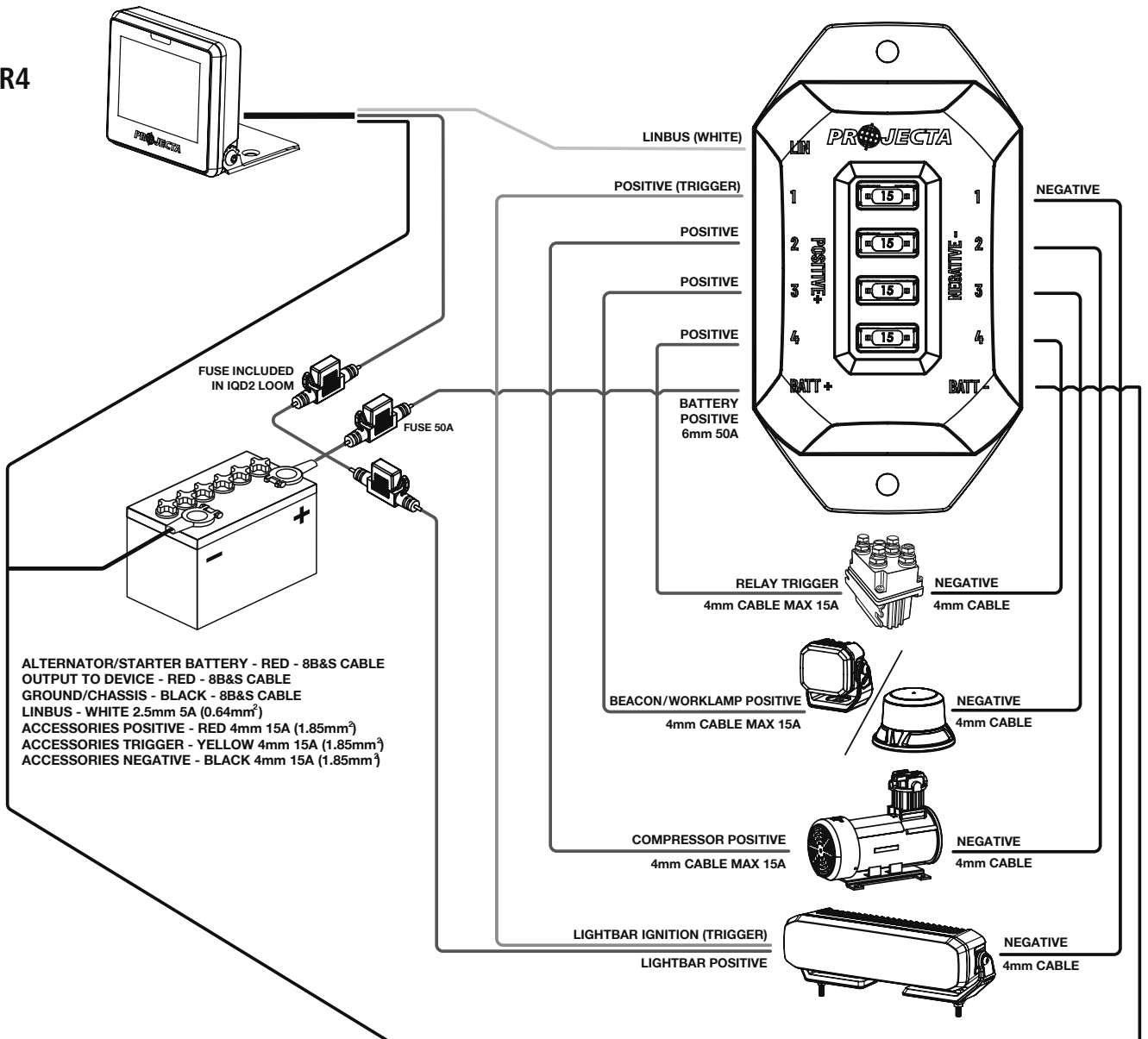

4. SYSTEM SETUP WITH IQ

Our smart relay products are part of the Intelli-IQ ecosystem and must operate under the control of an Intelli-IQ Controller, such as the IQD2 2-inch Smart Display. Users can control and operate the relays via the IQ controllers or the PROJECTA IQ APP on mobile devices.

For installation and setup instructions of IQ controllers and PROJECTA IQ APP, please refer to their manual.

4.1 Main Display Screen Layout

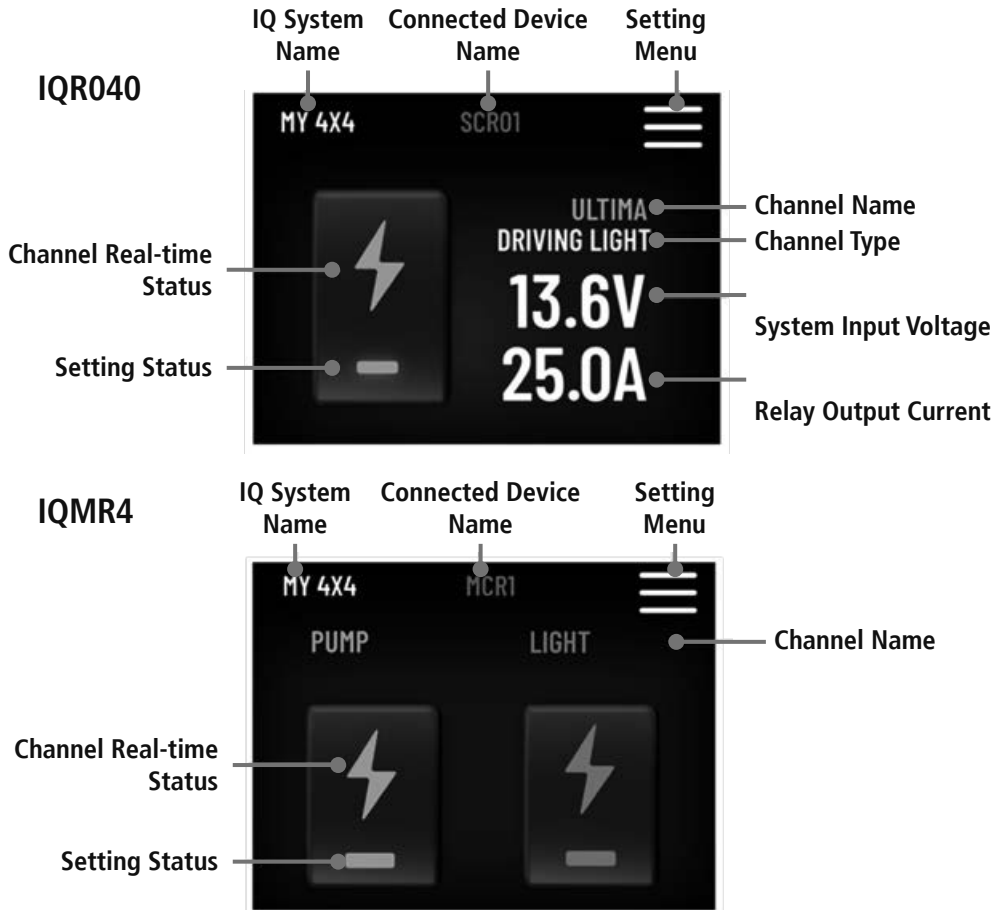

STEP	INSTRUCTION	DISPLAY
1	Before connecting Smart Relay, ensure IQD2 Firmware is updated via Mobile App to at least 1.1.X. After installation, wiring, and powering on the Smart Relays (IQR040 or IQMR4) and IQD2, simply reset the IQD2 by pressing IQ RESET button. The connected Smart Relays will automatically appear on the IQD2 display, allowing channel control and status monitoring directly from the device. For advanced settings, please use the IQ App. (If Mobile App requires a PIN to connect mobile Phone to IQD2, locate PIN on the 3rd page of IQD2 settings.)	
2	All channels of IQR040 and IQMR4 connected to the system will be displayed on the IQD2. You can swipe left to right to switch from one device type to another; IDCX to IQR040 to IQMR4. Swipe up and down to monitor other channels of same device type; from one IQR040 to the next IQR040, or from channels of IQMR4 to its other channels. Tap the Channel button for ON/OFF.	
3	When the IQR040 detects an overvoltage or overcurrent condition, the system input voltage or relay output current will be highlighted in red on the display, and the relay will automatically switch off.	

5. SMART RELAYS ON INTELLI-IQ APP INSTRUCTION

5.1 Setup The Relays

INSTRUCTION

Once a new relay is detected by the IQ, you will be notified by an in-app notification.

You can then slide to the Relay dashboard which will show you the available Relay devices.

This is called the **Relay Dashboard**.

You can configure the Relay Settings either directly through the dashboard, or through the device settings page.

DISPLAY



SET RELAY NAME

Tap the name of the IQ in the top left of the app main dashboard to enter the device settings. Once there, tap the relay name to enter the relay settings.

On the dashboard you can tap on the relay name to enter the relay settings page.

Here you can configure the relay depending on the usecase you require. Initially you can customise the name, style, icon and highlight colour.

The unit name can only be **6 characters**. Type the name and either tap return on the keyboard or tap another setting to update the name.

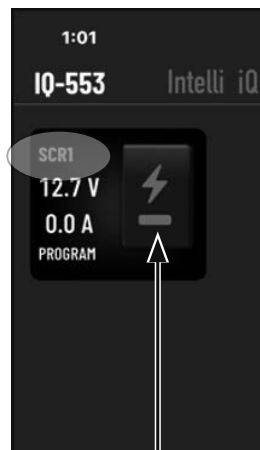

Press the button to turn on/off the relay

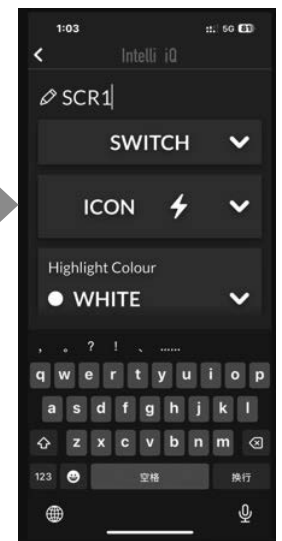
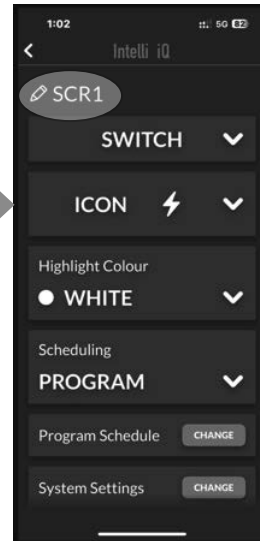

5.1 Setup The Relays cont.

INSTRUCTION

CHANGE WORKING MODE

The use case of the relay is managed by the top selection. This setting is set as SWITCH by default.

Depending on your use case and connected relay device, set this to one of SWITCH, LIGHTING, DRIVING LIGHT or VSR.

Depending on your use case, you can select an icon for your relay. Different icons are available for Switch and Lighting use cases. The VSR setting provides only one icon option which cannot be adjusted.

DRIVING LIGHT and VSR are only available on the IQR040 model.

DISPLAY



CHANGE HIGHLIGHT COLOUR

You can select a highlight colour from one of four options, White, Blue, Green and Orange.

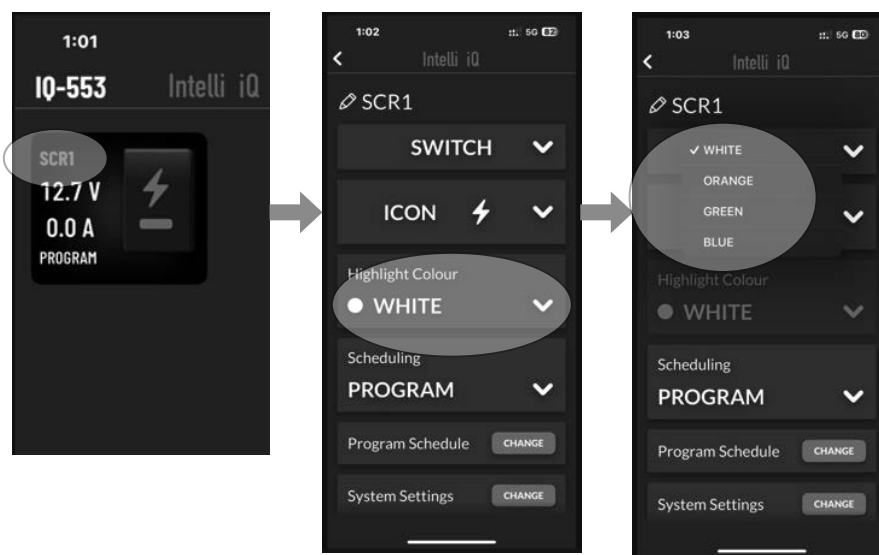

5.2 IQR040 Setup

On the relay dashboard, the IQR040 shows a single tile that include status information and control to switch the device on and off.

The switch toggle for the relay on the right hand side can be pressed to turn the relay on and off. The bottom indicator light of the toggle shows the state of the switch. If the indicator light is highlighted, the relay is attempting to turn on the connected device. If the icon and relay name are highlighted then the device connected to the relay is also on. If the indicator light is grey, the relay is attempting to turn off the connected device. If the icon and relay name are grey, this means the device connected to the relay is off.

On the left hand side starting from the top the user is presented with the relay name, voltage, current and setting of the relay.

The voltage display shows the potential voltage of the relay. It will turn red if it is under or over the limits set in the relay.

The current display shows the number of amps running through the relay. It will turn red if it is over the maximum current setting of the relay. If no current is detected, the value will be displayed as a 0.0A

The relay setting display will indicate one of the following values depending on the status of the relay.

PROGRAM: The relay is running in the Schedule Program mode.

OFF DELAY: The relay is running with an Off Delay.

D-LIGHT: The relay is set to run in Driving Light mode.

VSR: The relay is set to run in VSR mode.



VOLTAGE SETTING

In the relay settings screen, scroll down and tap the "System Settings – Change" button.

To change the voltage of device connected to the relay, tap the "System Voltage". You can select one of two options 12V and 24V.

MAXIMUM CURRENT SETTING

In the relay settings screen, scroll down and tap the "System Settings – Change" button.

Use the slider to adjust the maximum current. For 12V relays, the maximum current is 40A and for 24V relays, the maximum current is 15A.

AUTO RESTART SETTING

In the relay settings screen, scroll down and tap the "System Settings – Change" button.

To setup the relay so that it restarts automatically after the current of the relay enters a valid range. If this setting is off, the relay will not automatically restart when current enters a valid range.

LOW and OVER VOLTAGE SETTING

In the relay settings screen, scroll down and tap the "System Settings – Change" button.

When the relay is set as a LIGHTING, SWITCH or DRIVING mode you can set the LOW and OVER Voltage setting. The value ranges scale depending on which voltage you have selected, either 12V or 24V. If a relay goes outside this range, the relay will automatically switch off the connected device.

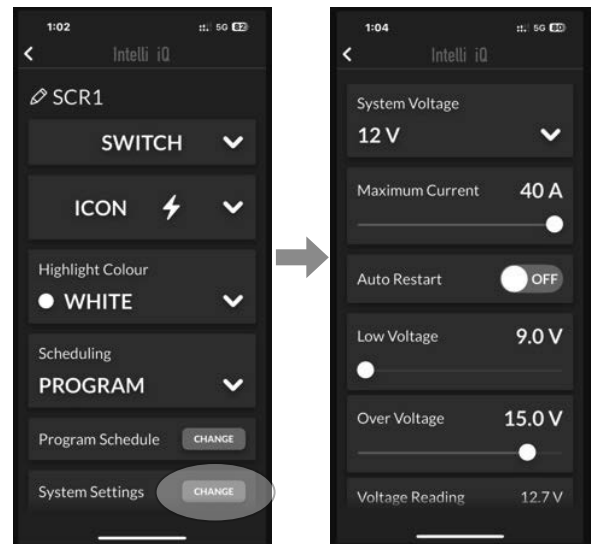

5.2 IQR040 Setup

SCHEDULE SETTING

In the relay settings screen when the relay is set to SWITCH, LIGHTING or DRIVING LIGHT, you can adjust the type of schedule activity.

Tapping on the schedule type you can choose either PROGRAM or OFF DELAY.

PROGRAM allows specific schedule date and time event programs to be set. There are up to 4 events which you can define. Each event allows you to specify a start time, end time and which days the events run on. Setting the end time before the start time will turn off the relay the following day. For example if a LIGHTING relay has a program that starts at 10:00pm and ends at 10:00am, and is set on for Monday. The relay will turn on at 10:00pm Monday evening and turn off 10:00am Tuesday morning.

Event times cannot overlap. If an overlap of events is detected, an indicator at the top of the page is presented. The text will state which two events are overlapping. Be mindful of events which overlap where the event end time is before the start time, as this would mean the event ends the next day.

Selecting Prioritise schedule will keep the schedule running even if the LIN connection has been lost to the relay, this allows relays to keep the schedule to keep running even though the IQ is disconnected.

When this schedule mode is selected, the relay will indicate PROGRAM on the dashboard toggle.

After you have completed setting up your events, tap on SAVE in the top right corner of this page to confirm your changes.

If you would like to discard your changes, select CANCEL and then confirm cancellation of any changes.

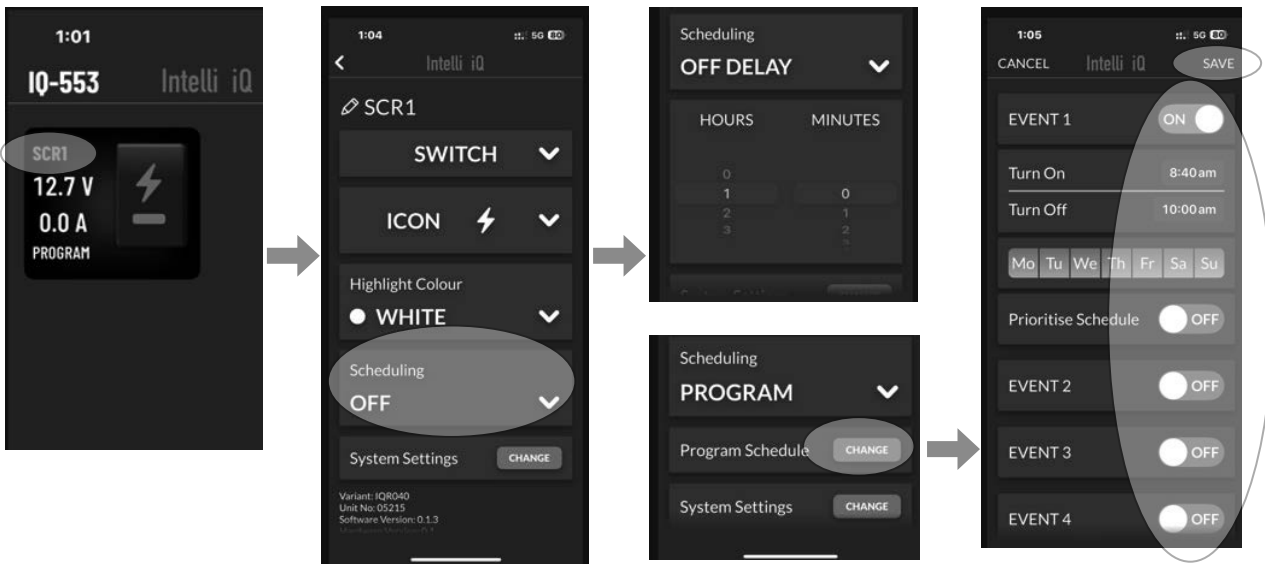

SETTING the SCHEDULE to OFF DELAY MODE.

OFF DELAY shows a period of time until the RELAY is turned off. You can choose from 1 minute to 3 hrs 59 minutes off delay time.

When relay is set to Schedule OFF DELAY, after turning off the relay, the connected device will turn off after the specified delay time.

When this schedule mode is selected, the relay will indicate OFF DELAY on the dashboard toggle.

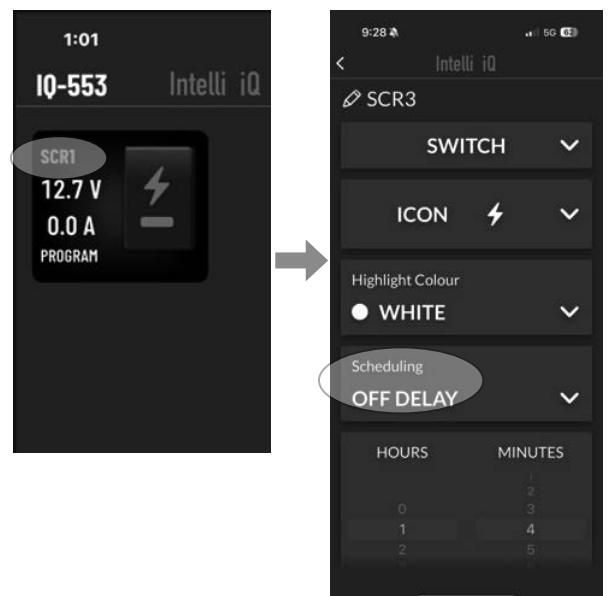

5.2 IQR040 Setup

VOLTAGE SENSITIVE RELAY SETTING

When VSR mode is activated, the Relay is now a Voltage Sensitive Relay (for 12V only). The relay will activate into it's ON state when the input voltage goes over the VSR Cut In Voltage and will turn OFF when the voltage drops below the VSR Cut Off Voltage.

The VSR voltage cutoff settings are located in the relay system settings, located at the bottom of the relay settings page.

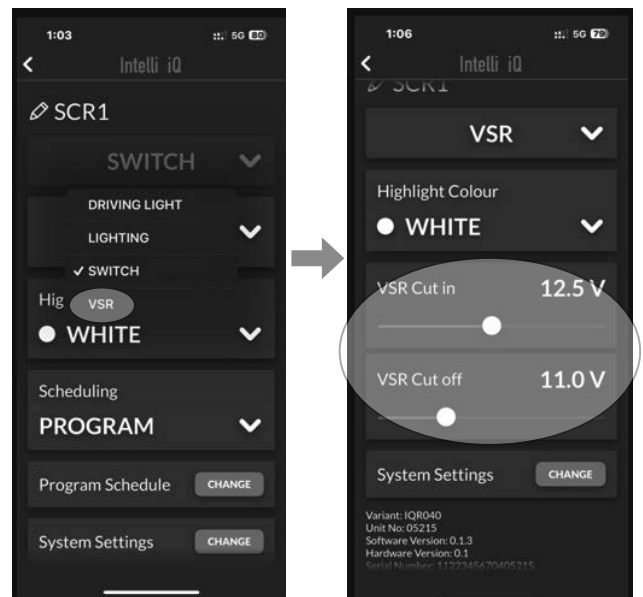

FLASH PATTERN SETTING

When the relay is set to LIGHTING mode, you can select one of a number of flash patterns.

The SOS pattern will flash three times with a short flash, followed by three time of a longer flash.

When selecting CUSTOM, you can specify the flash on and off time.

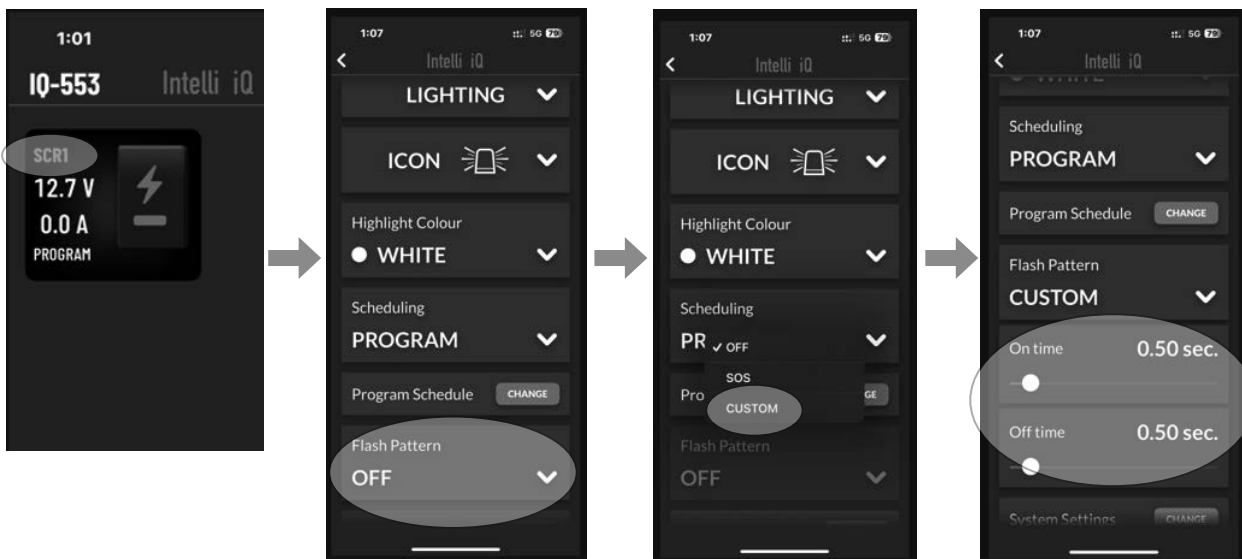

5.3 IQMR4 Setup

On the relay dashboard, the IQMR4 shows a large 2x2 tile that shows four channels of the relay. On the top left the relay name is shown, followed by the voltage of the relay.

The voltage reading indicates the total voltage reading for the relay. If the voltage is below the low voltage settings or greater than the above voltage setting, this indicator will highlight in red.

Inside the large tile each channel is shown on one tile has an information indicator, including the name of the relay channel and the switch toggle.

The switch toggle for the channel on the right hand side can be pressed to turn the channel on and off. The bottom indicator light of the toggle shows the state of the switch. If the indicator light is highlighted, the channel is attempting to turn on the connected device. If the icon and channel name are highlighted then the device connected to the channel is also on. If the indicator light is grey, the channel is attempting to turn off the connected device. If the icon and channel name are grey, this means the device connected to the channel is off.

The relay setting display will indicate one of the following values depending on the status of the relay.

PROGRAM: The relay is running in the Schedule Program mode.

OFF DELAY: The relay is running with an Off Delay.

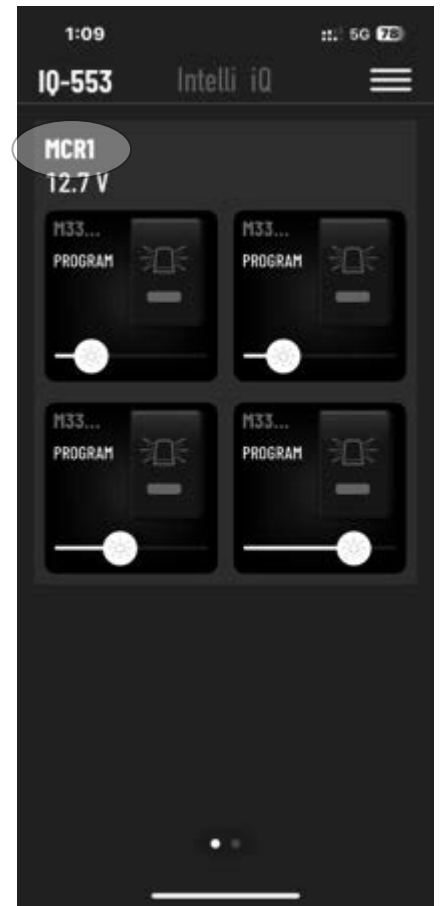

VOLTAGE SETTING

In the relay settings screen, scroll down and tap the "System Settings – Change" button.

On this page you can adjust the LOW and OVER Voltage settings. If the relay voltage either falls below low voltage or goes over voltage, the relay will automatically switch off all channels.

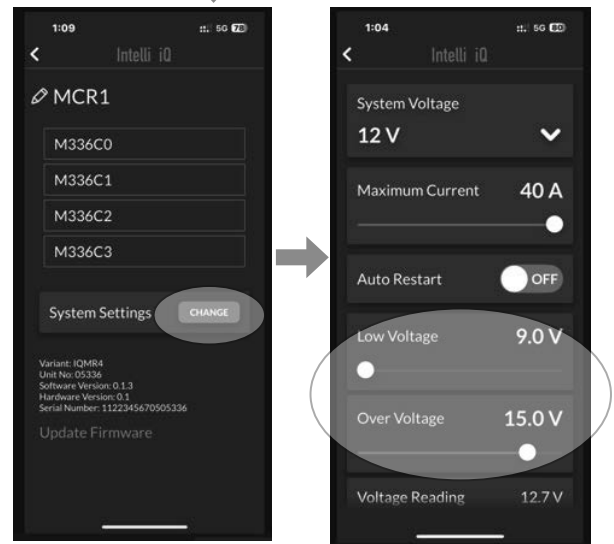

5.3 IQMR4 Setup

SETTING the SCHEDULE to OFF DELAY MODE.

OFF DELAY shows a period of time until the channel is turned off. You can choose from 1 minute to 3 hrs 59 minutes off delay time.

When the channel is set to Schedule OFF DELAY, after turning off the relay, the connected device will turn off after the specified delay time.

When this schedule mode is selected, the channel will indicate OFF DELAY on the dashboard toggle.

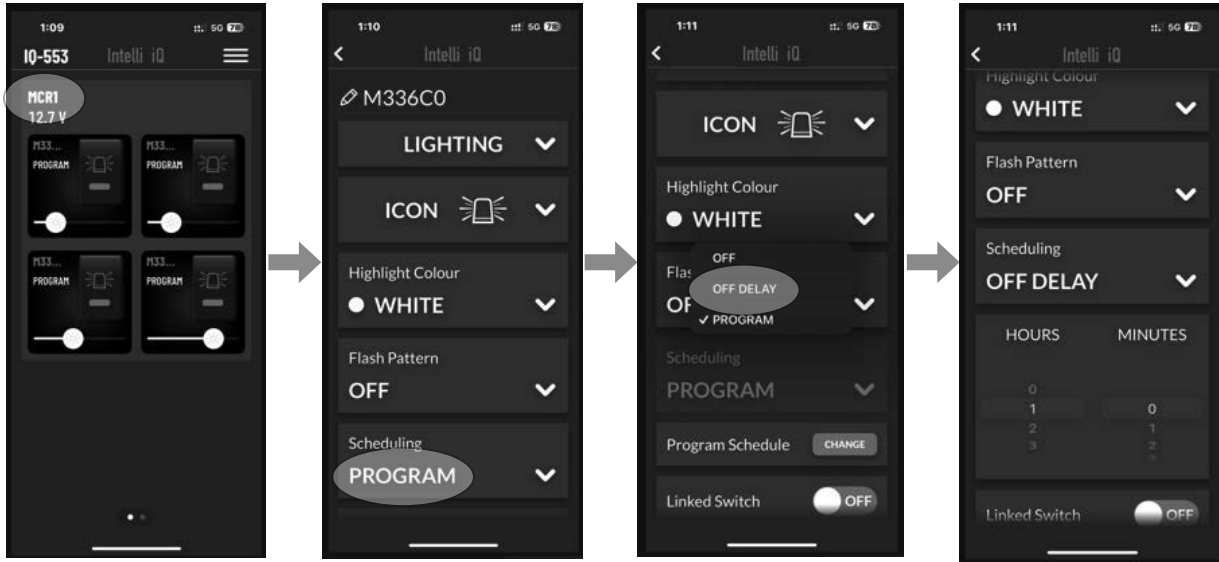

SETTING LIGHTING MODE

When the relay is set to LIGHTING mode, you can select one of a number of flash patterns.

The SOS pattern will flash three times with a short flash, followed by three times of a longer flash.

When selecting CUSTOM, you can specify the flash on and off time.

An additional set of industry standard patterns are available, including the following:

Pattern 1: Single Flash

Pattern 2: Quint Flash

Pattern 3: Deca Flash

Pattern 4: Fast Flash

Pattern 5: Double Flash

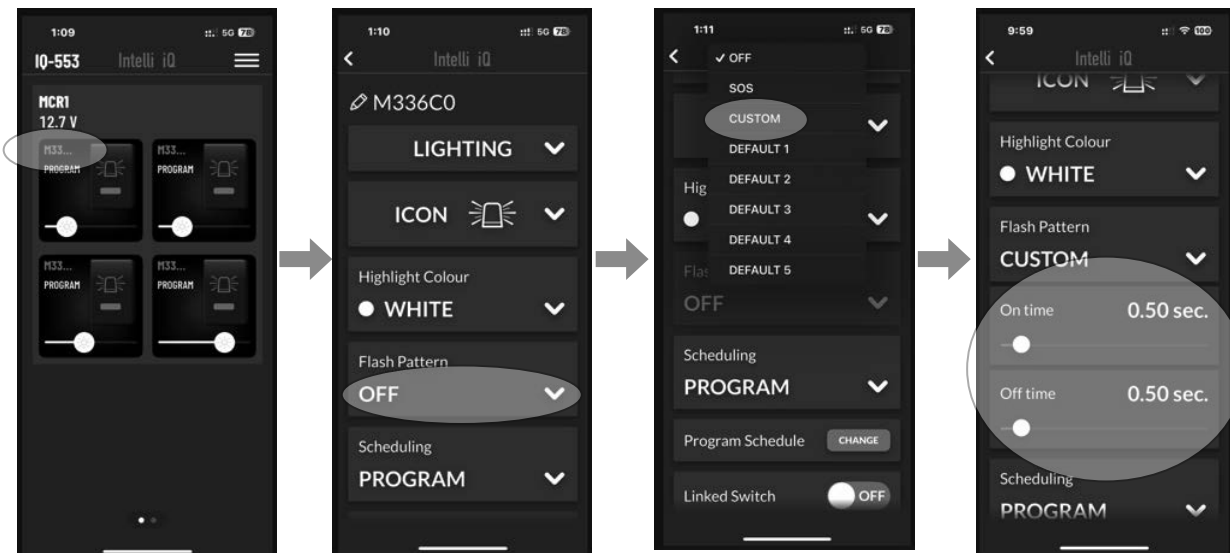

5.3 IQMR4 Setup

SETTING LINKED SWITCH TOGGLE

In the relay channel settings page, scrolling to the bottom of the page is the LINKED SWITCH toggle.

When LINKED SWITCH is turned on, the selected channel is linked to it's corresponding channel. So that channel 1 is linked to channel 2, channel 3 will be linked to channel 4.

When the two channels are linked, their toggle on/off switch will toggle the other channel off if the current channel is on. For example, if channel 1 and 2 are linked, and channel 2 is on, turning channel 1 on will turn channel 2 off.

The dashboard layout will display a single toggle combining the two channels.

When two channels are linked, the following settings are shared, the mode of the relay which is LIGHTING or SWITCH, the icon which depends on the mode, the highlight colour and the scheduling settings.

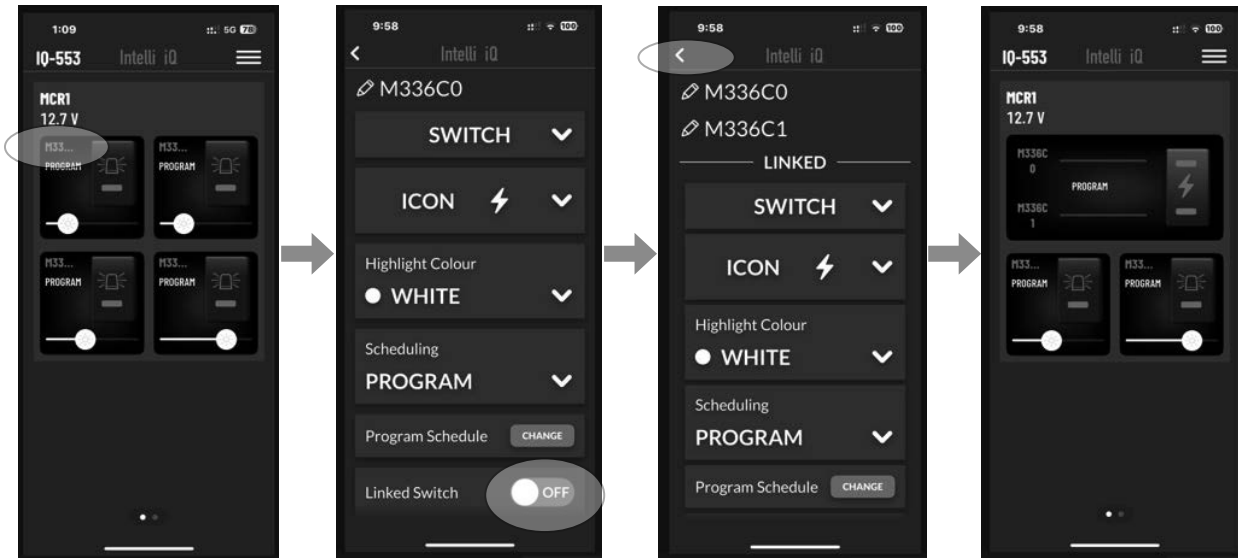

When a relay channel is set to lighting mode, on the dashboard you will see a slider visible for the channel.

This slider can be used to adjust the brightness of the light connected to the relay channel.

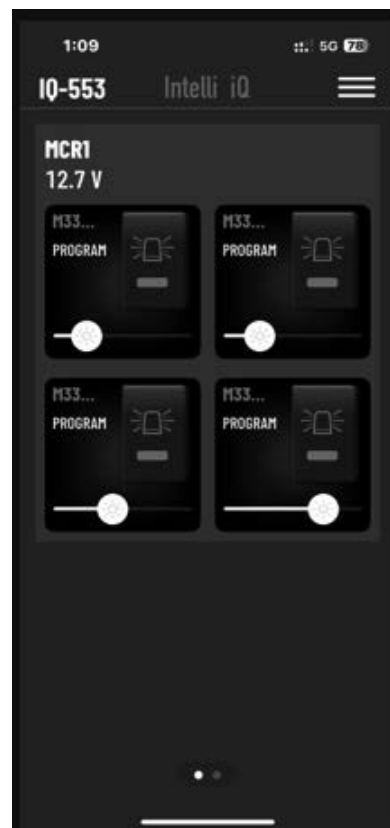

6. SMART RELAYS ON CARPLAY/ANDROID AUTO INSTRUCTION

The iQ app supports iOS CarPlay and Android Auto. Please update the app to the latest version before use. Once your IQD2 (or any other IQ controller) is connected to the corresponding Mobile App, IQ Smart devices may then appear in your compatible vehicle display system.

IQ HOME DISPLAY

On the Home page, you can view all devices connected to the INTELLI-IQ system, including each channel of your IQR040 or IQMR4. You can also quickly toggle them on or off.

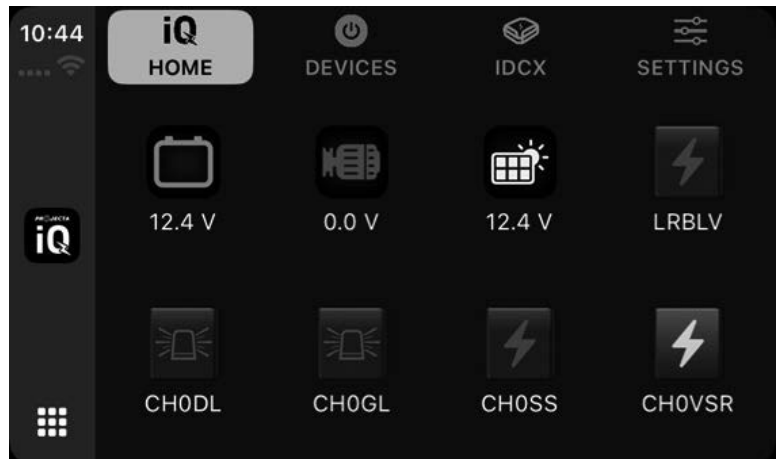

DEVICES DISPLAY

Switch to the DEVICES interface by selecting the tab at the top.

In this interface, only the channels of all IQR040 and IQMR4 devices will be displayed.

Tap the corresponding icon to toggle the switch.

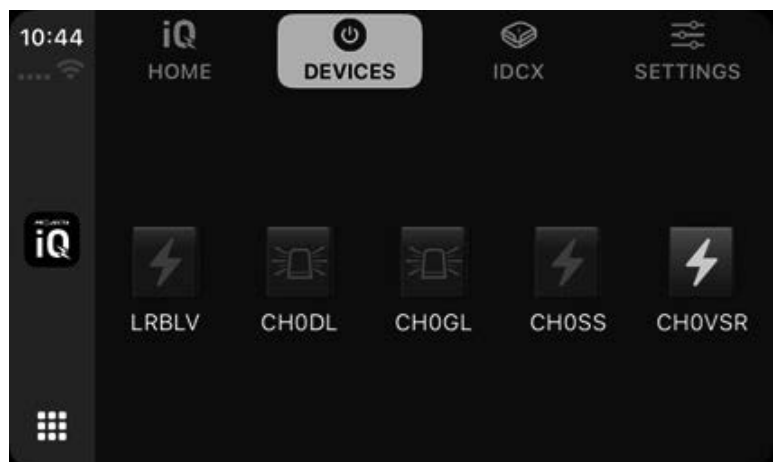

SETTING DISPLAY:

Switch to the SETTING interface by selecting the tab at the top.

Select the Channel you wish to view or adjust settings for to enter the configuration screen.

The SETTING interface shows each CHANNEL's current status, including type, Schedule, and OFF DELAY settings.

Tap the BRIGHT button to increase brightness in 10% increments, up to a maximum of 100%.

Tap the DIM button to decrease brightness in 10% increments, down to a minimum of 10%.

Tap the Pattern button to cycle through 5 default patterns and the CUSTOM pattern.

Please note: Brightness adjustment is only available when IQMR4 is in lighting mode

For more advanced settings, please use the mobile device app.

CARPLAY/Android Auto only supports basic operations that do not interfere with driving.

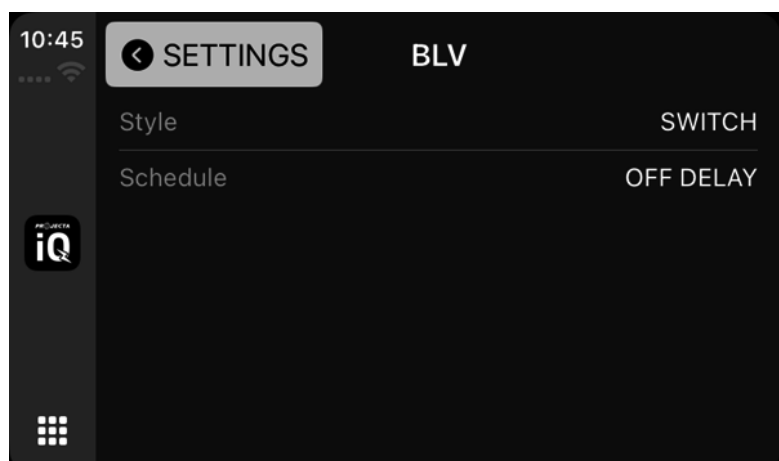
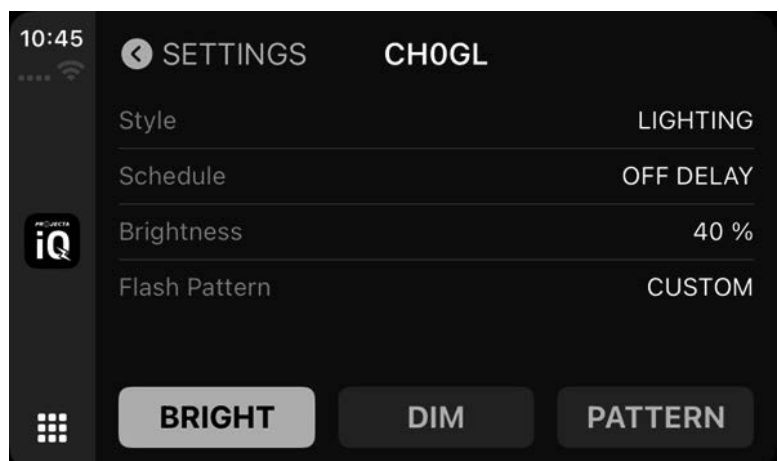

WARRANTY STATEMENT

Brown & Watson International Pty Ltd ("BWI") of 1500 Ferntree Gully Road, Knoxfield, Vic., telephone (03) 9730 6000, fax (03) 9730 6050, warrants that all products described in its current catalogue will under normal use and service be free of failures in material and workmanship for a period of five (5) years from the date of the original purchase by the customer as marked on the invoice. This warranty does not cover ordinary wear and tear, abuse, alteration of products or damage caused by the purchaser.

To make a warranty claim the consumer must deliver the product at their cost to the original place of purchase or to any other place which may be nominated by either BWI or the retailer from where the product was bought in order that the warranty assessment may be performed. The consumer must also deliver the original invoice evidencing the date and place of purchase together with an explanation in writing as to the nature of the claim. In the event that the claim is determined to be for a minor failure of the product then BWI reserves the right to repair or replace it at its discretion.

In the event that a major failure is determined the consumer will be entitled to a replacement or a refund as well as compensation for any other reasonably foreseeable loss or damage. This warranty is in addition to any other rights or remedies that the consumer may have under State or Federal legislation.

IMPORTANT NOTE

Our goods come with guarantees that cannot be excluded under the Australian Consumer Law. You are entitled to a replacement or refund for a major failure and compensation for any other reasonably foreseeable loss or damage. You are also entitled to have the goods repaired or replaced if the goods fail to be of acceptable quality and the failure does not amount to a major failure.

Distributed by

AUSTRALIA

Brown & Watson International Pty Ltd

Knoxfield Victoria 3180
Telephone (03) 9730 6000
Facsimile (03) 9730 6050
National Toll Free 1800 113 443

NEW ZEALAND

Brown & Watson International NZ Ltd.

Mount Wellington Auckland 1060
Telephone (09) 525 4575

IS659

Issue 30/04/25